

TYPICAL INTERSECTION WITH VALLEY GUTTER

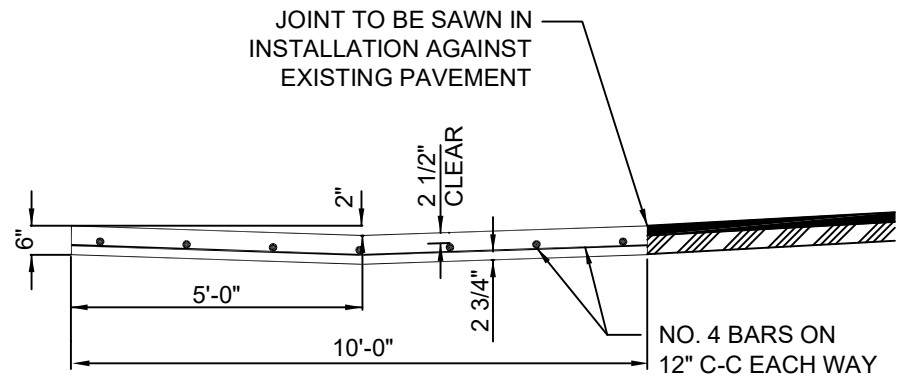

VALLEY GUTTER CROSS-SECTION

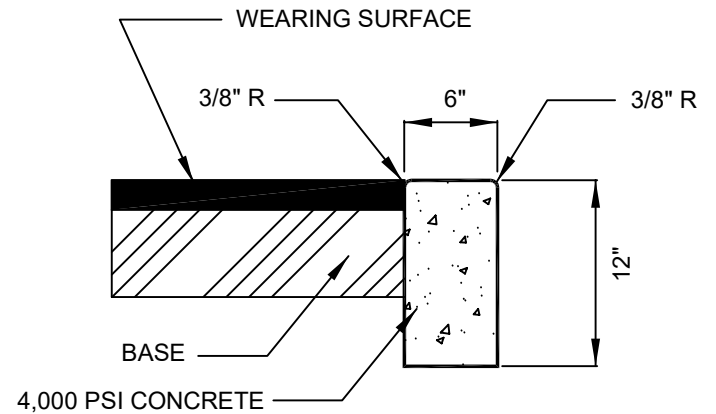

CONCRETE HEADER CROSS-SECTION

NOTES:

1. ARROWS INDICATE DRAINAGE FLOW.
2. ALL RADII SHALL BE AS SHOWN ON THE PLANS.

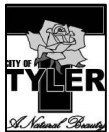

CITY OF TYLER
STANDARD DETAIL

**VALLEY GUTTERS AND
CONCRETE HEADERS**

REVISION DATE:
MAY 14, 2021